

# WIDE FLAT 24V-DC

IP69

14W - 1700Lm

28W - 3400Lm

56W - 6800Lm

5.600 - 6.000°K - 40.000h

RoHS RAEE CONFORMITY



cavo senza spina  
cable without plug

## CARATTERISTICHE

Fino all'85% di risparmio energetico  
Basso calore  
Zero manutenzione  
Struttura in alluminio  
Dotata di vetro ad alta resistenza e griglia di lenti anti-irritazione per gli occhi  
Resistente ai lubro-refrigeranti  
Direttive 2006/95/CE, 2004/108/CE e 2006/42/CE come previsto dalla Normativa UNI EN 1837

### Standard:

- Modulo Led con angolo 120°

### 3 versioni di potenza:

- 14W: 1 set di Led da 14W
- 28W: 1 set di led da 28W
- 56W: 2 set di Led da 28W

## FEATURES

*Up to 85% energy saving  
Low performing heat  
Zero maintenance  
Aluminium structure  
Equipped with high resistance glass and anti-irritation lens grid  
Resistant to coolants and lubricants  
Complies with Directives 2006/95/EC, 2004/108/EC and 2006/42/EC as required by Normative UNI EN 1837*

### Standard:

- 120° LEDs Module

### 3 power options:

- 14W: with 1 set of LEDs 14W
- 28W: with 1 set of LEDs 28W
- 56W: with 2 set of LEDs 28W

# WIDE FLAT 24V-DC - 14W - 28W - 56W - IP69



14W - 1700Lm	ART.	CODE	VIN	WxLed	cable.mt	Kg
--------------	------	------	-----	-------	----------	----

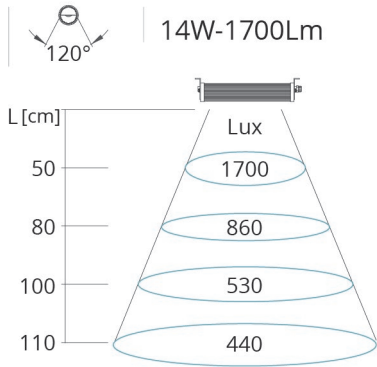

WIDE F-14W-24V-DC	09.02.2.12.14.3	24V-DC	14W	1,80	1,00
-------------------	-----------------	--------	-----	------	------

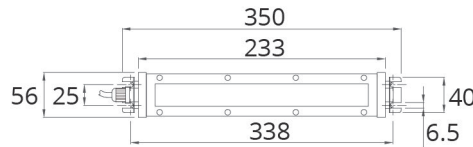

SCATOLA MADRE  
MASTER BOX



Qty: 10 pcs  
Dimensions: 42x35x28 cm  
Weight: 10 Kg

28W - 3400Lm	ART.	CODE	VIN	WxLed	cable.mt	Kg
--------------	------	------	-----	-------	----------	----

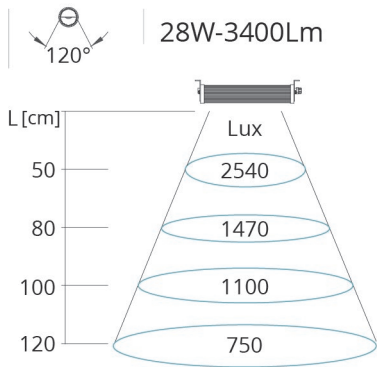

WIDE F-28W-24V-DC	09.04.2.12.28.3	24V-DC	28W	1,80	2,20
-------------------	-----------------	--------	-----	------	------

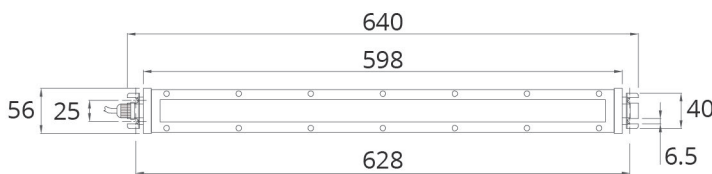

SCATOLA MADRE  
MASTER BOX

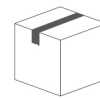

Qty: 6 pcs  
Dimensions: 75x30x38 cm  
Weight: 15 Kg

56W - 6800Lm	ART.	CODE	VIN	WxLed	cable.mt	Kg
--------------	------	------	-----	-------	----------	----

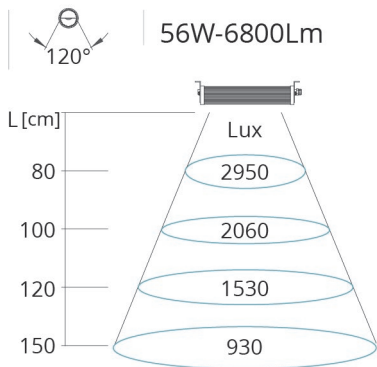

WIDE F-56W-24V-DC	09.06.2.12.56.3	24V-DC	28Wx2	1,80	2,75
-------------------	-----------------	--------	-------	------	------

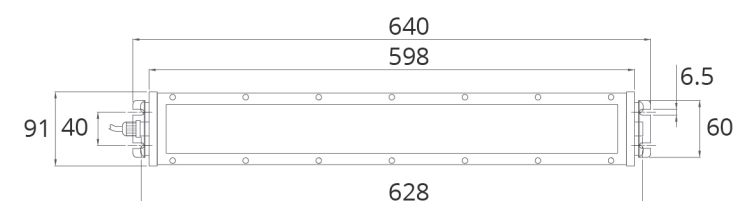

SCATOLA MADRE  
MASTER BOX



Qty: 4 pcs  
Dimensions: 75X31X27 cm  
Weight: 12Kg